

## QUOTATIONS FOR SCIENTIFIC EQUIPMENTS – CENTRE FOR GREEN ENERGY TECHNOLOGY

Sealed quotations under **two bid** system are invited for the purchase of Major and Minor scientific equipments under the CSIR Research Project Grant. The technical specifications of the equipments are listed below. All the tenders should be sent to the following address

Dr.R.Prasanth,  
Centre for Green Energy Technology,  
Pondicherry University,  
R.V Nagar, Kalapet,  
Pondicherry – 605014

The last date for the submission of tender is May 15, 2015, 03.00 PM

S.No	Name of the equipment with specification	Quantity
1.	<p style="text-align: center;"><b>Digital Weighing Balance</b></p> <ul style="list-style-type: none"><li>1) Capacity: 120 g</li><li>2) Readability: 0.1 mg</li><li>3) Repeatability: <math>\pm 0.1</math> mg</li><li>4) Linearity: <math>\pm 0.2</math> mg</li><li>5) Pan Size: 90 mm</li><li>6) Response Time: 3 – 4 sec</li><li>7) Calibration: Automatic External</li><li>8) Tare Range: Full</li><li>9) Operating Temperature: 10° C to 40° C</li><li>10) Power Supply: AC 220 V single phase, 50 Hz</li><li>11) Data Output: RS 232 C</li></ul>	1

## 2. Heat flux analyzer

The complete design with proper dimensions is given in the schematic

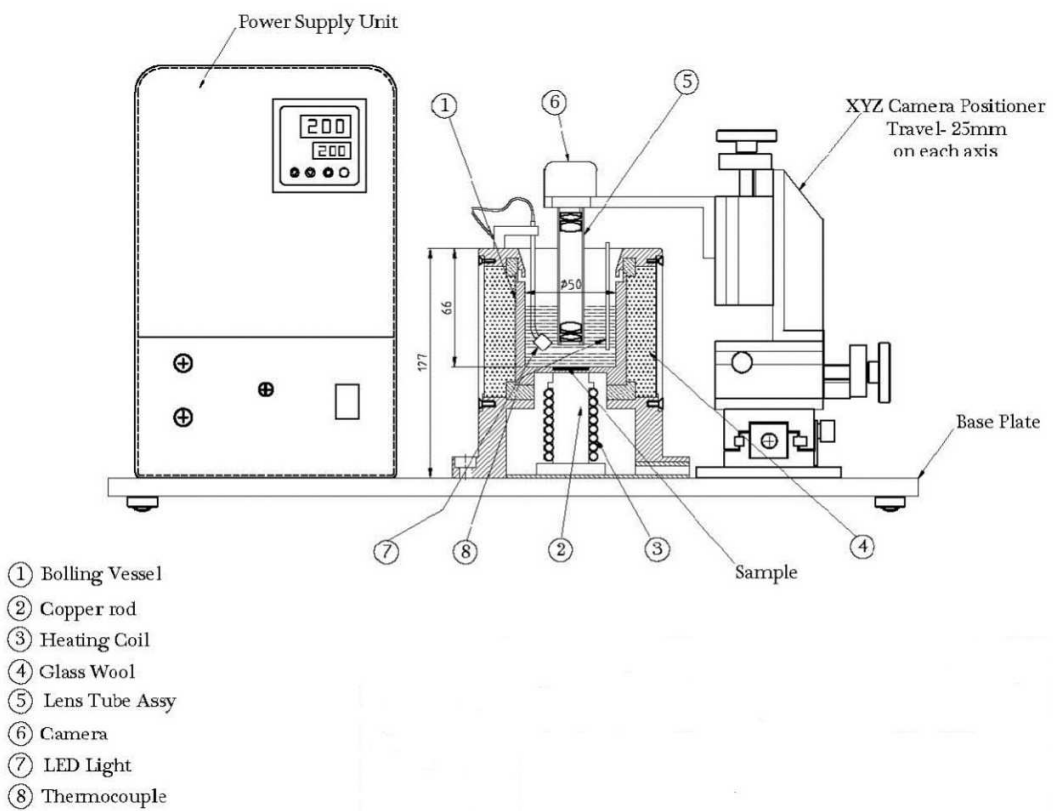
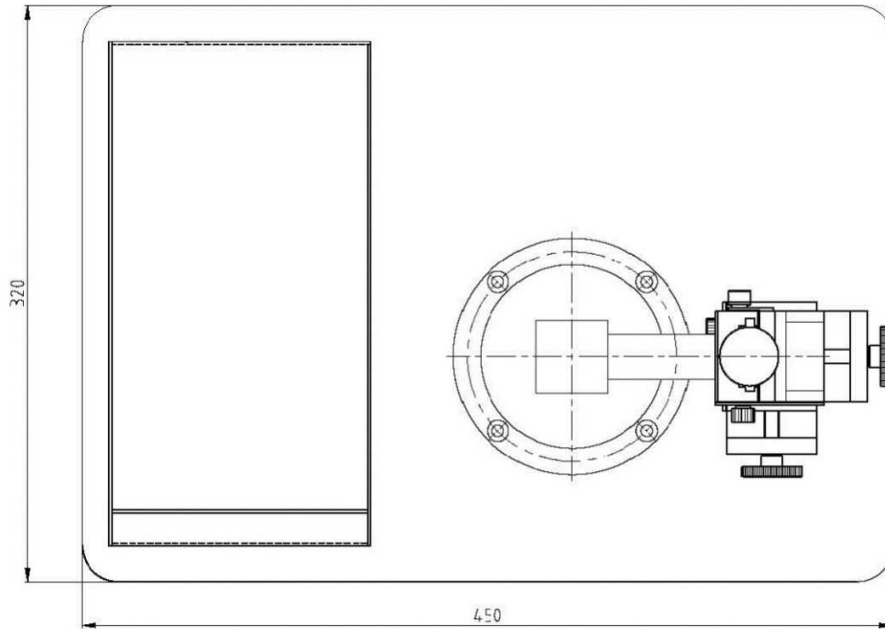

3.	<p style="text-align: center;"><b>Muffle Furnace</b></p> <ol style="list-style-type: none"> <li>1) Maximum Temperature: 1200°C</li> <li>2) Operating Temperature: 1100°C</li> <li>3) Size of Heating Chamber (W x H x D): 5" x 5" x 10"</li> <li>4) Controller: Multiprogrammable PID controller to program digitally ( Provide the technical details of the PID controller including Make and Model)</li> <li>5) Rate of Heating: 2-10°C/ minute</li> <li>6) Accuracy: ±1°C</li> <li>7) Input power: AC 220V, 50 Hz, Single phase</li> <li>8) Heating element: 'Kanthal A'</li> <li>9) Appropriate ceramic insulation to avoid thermal loss</li> </ol>	1
4.	<p style="text-align: center;"><b>Centrifuge</b></p> <ul style="list-style-type: none"> <li>• BenchTop model High Speed Centrifuge system</li> <li>• Programmable microprocessor controlled high performance centrifuge</li> <li>• Dual digital display of set and actual settings, key pad entry</li> <li>• Max Capacity: 500 ml</li> <li>• Max Speed: 15000 rpm or more</li> <li>• Temperature: 20°C to 45°C</li> <li>• 2 Optional Rotors</li> </ul>	1

	<ul style="list-style-type: none"> <li>• 5 x 100 ml and 25 x 20 ml propylene tubes</li> </ul>	
5.	<p style="text-align: center;"><b>Magnetic Stirrer with Hot plate</b></p> <ul style="list-style-type: none"> <li>• IKA make</li> <li>• Dimension of Plate: 15 cm x 15 cm or above</li> <li>• Powerful motor for stirring quantities of up to 2 litres</li> <li>• Temperature Range: 50°C to 500°C</li> <li>• Hot Top indicator</li> <li>• Separate knob for controlling temperature and Stirring Speed</li> <li>• Elevated control panel for protection against leaking liquids</li> </ul>	1
6.	<p style="text-align: center;"><b>pH meter</b></p> <ul style="list-style-type: none"> <li>• Measuring range: -2.00 to 14.0</li> <li>• In built temperature indicator</li> <li>• Temperature range: -5 C to 100C</li> <li>• Accuracy: 0.01pH &amp; 0.2 C</li> <li>• Readability: 0.001 pH &amp; 0.1 C</li> <li>• Auto calibration: 2 points or 3 points</li> <li>• Buffer solution : pH – 4 and pH - 10</li> </ul>	1
7.	<p style="text-align: center;"><b>Bath Sonicator</b></p> <ul style="list-style-type: none"> <li>• Heated cleaning up to 75°C</li> </ul>	

	<ul style="list-style-type: none"> <li>• Fully programmable with timer</li> <li>• Volume: 2L</li> <li>• Frequency: 40 KHz</li> </ul>	1
--	--	---

## **TERMS AND CONDITIONS**

### **I. General Information: -**

1. Last date and time of receipt of the Tenders: 15.5.15, 3.00 PM

2. Date & Time of opening of Department-wise Tender: 22.5.15, 3.30 PM

3. Tender Document fee and EMD rates: -

**Tender Document Fee: Rs 500 /- (mandatory for all equipments)**

**EMD rate: 2.5 % of the quoted price (If price is above Rs 50,000)**

4. Two bid systems have to be strictly followed. (One for Technical bid and another for commercial bid to be submitted in separate covers)

5. However, the tender document fee and EMD as specified above should be remitted by each firm / bidder, collectively for all their bids advertised under this tender.

6. Quoting merely the lowest price does not confer any right to any bidder for award of supply order. The University's Purchase Committee, reserves the right to select the equipment any bid under the grounds of specification compliance, technologically advanced quality, proven performance track record, brand reputation, service backup support, additional warranty, offer of additional / special features, Compatibility with the existing System, Training, etc.

7. The Tender Document Fee and EMD should be submitted in a separate cover superscribing Bank Demand Draft and which should be enclosed with the technical bid.

8. The Photo Copies of the Bank Instruments on payment of EMD should be attached with each bidding covers.

9. The tender / quotation must be submitted along with the stipulated tender document fee and EMD in the sealed cover, super-scribing the name of the Department / Centre for whose equipments the tender is quoted for.

10. The cover should also contain the information like, Name of the Equipment and Serial Number of Equipments for which the bids are submitted. The name and address of the bidder should also be mentioned at the FROM address space

11. The tenders should be addressed to the Dr.R.Prasanth, Assistant Professor, Pondicherry University. The examples for super-scribing the envelopes of the different categories of tenders are given below: -

Tender submitted under two bid system for the Centre for Green Energy and Technology	
Name of the Equipment: _____	
	To
	Dr.R.Prasanth, Assistant Professor Center for Green Energy Technology Pondicherry University Kalapet 605014
From	
Supplier's Address	

## **II. Common Conditions**

### **1. Purchase of Tender Document:**

The Tender document can be either downloaded from the University website [www.pondiuni.edu.in](http://www.pondiuni.edu.in) or procured from the Information Facilitation Counter, Dr.Ambedkar Administrative Block, Pondicherry University on payment of fee as specified above, by means of

a D.D drawn in favor of the Finance Officer, Pondicherry University, payable at Puducherry. The downloaded application should be accompanied with the tender document fee, in the form of a Demand Draft. Separate bids should be submitted.

## **2. Price Schedule**

The bidder may either quote for the entire equipments or individual items required for the Centre for Green Energy and Technology. The rates should be quoted for a single unit and also for the total quantity required by the University. The price should include the Delivery, installation, training charges (if any), etc. at the respective Department, Pondicherry University. The prices quoted shall remain firm until equipment is supplied to the Centre for Green Energy Technology, Pondicherry University.

## **3. Quoting the Core price & Tax, Duties, Discount etc.**

The taxes / duties / discounts, if applicable, are to be explicitly and separately shown in the bid.

## **4. Eligibility:**

The firm must have the requisite domain expertise with regard to supply, installation and post-sale service of the items they are quoting. The firm should have been in existence for at least six years as on the date of this tender and must have executed at least three orders for this kind of equipment during the last three years.

## **5. Duty Exemption**

The University has been granted the benefit of exemption from the payment of the Central Excise Duty and Customs Duty by the Department of Scientific and Industrial Research (DSIR), India, vide their Notification No.10/97 dt. 01-03-1997 and 51/96 dt. 23.07.96 respectively,

### **in respect of**

a. Scientific and technical instruments, apparatus, equipment including computers.

- b. Accessories and spare parts of goods specified in (a) above and consumables.
- c. Computer software, compact disks, CD ROM, Recording magnetic tapes, microfilms, micro-chips etc.
- d. Prototypes.

Customs duties at Indian port, if any, will be to the account of the University.

#### **6. Warranty:**

The material covered under the purchase order, when installed, shall be warranted for the quality, workmanship, trouble free operation and performance for a period of at least 36 months from the date of putting the system into operation at the Pondicherry University, or at least 42 months from the date of receipt of the last lot of the consignment in India. If any item covered under warranty fails, the same shall be replaced free of cost including all the applicable charges including shipping cost both ways.

7. The information pertaining to infra-structural, power and any other requirement for satisfactory installation and commissioning of the whole system must be provided by the bidder, at least 120 days in advance of the installation to be commenced if purchase order is issued. All drawing for electrical connections, electrical safety items piping work etc. must be provided in detail.

8. Complete technical specifications and literature, including process flow, to be included with the quotation. Manufacturers of various major parts/equipment must be mentioned explicitly.

9. A clear statement regarding availability of after-sales service and availability of spare parts for next 5 to 10 years should be included.

10. A recent customer list (within last five years) with contact details including email address is to be submitted with technical bids / bids as the case may be.



11. If the bidder is an authorized representative in India, they are requested to inform their technical ability to take care of the problems in the system, if developed later within the warranty and outside the warranty period. The responsibility of the Indian agent must be clearly specified.

12. The bidder from abroad shall obtain, if required, export permission from the appropriate authorities in his country or the country of origin for items to be shipped to India in case of items to be imported. The University shall provide necessary information if required for this purpose.

13. All equipment must operate at 230V/50 Hz single phase and / or equivalent three phase electrical power.

14. The validity of the each quotation should be at least 1 Year from closing date of the bid.

15. The offers will not be considered if received after the bid closing date and time.

16. The offers received through telex / tele-fax / e-mail will not be accepted by the University under any circumstances. 17. The University shall not be responsible for any delay / loss or non-receipt of tenders by post / courier service.

18. No unsolicited correspondence shall be entertained after the submission of the offer.

19. If an order is placed with the firm, the purchase shall be governed by an agreement as per the University rules in force at the time.

20. Additional terms and conditions will be incorporated in the purchase order, if needed, to safeguard the interests of the University.

21. Tender is not transferable.

22. In case of any dispute in respect of the tender, all legal matters shall be instituted within the jurisdiction of the place where the purchaser ordinarily resides.

23. Power to reject the offer:

Pondicherry University reserves the right to accept / reject any offer in full or in part or accept any offer other than the lowest offer without assigning any reason thereof. Any offer containing incorrect and incomplete information shall be liable for rejection.

24. No Agency commission will be paid to any authorized agent in India.

25. Liquidated damages: Timely supply of the ordered items, installation, commissioning (wherever is applicable) and training etc. is the essence of the contract. In case of failure to supply within the time specified in the Purchase order, a penalty/LD of 0.5% of the total value per week or a part thereof shall be levied subject to a maximum of 7.5% in respect of items which are not supplied. The decision of Pondicherry University shall be final in this regard.

26. The training should be provided by the supplying companies on the specimen and operation of the equipments for a minimum period of two weeks from the date of installation with an expert team.

27. For any clarification with respect to technical specifications, please contact as per the details given below: -

S.No	Name of the Department	Name of the Principal Investigator	Contact Numbers
1	Centre for Green Energy Technology	R.Prasanth	0413-2655987

### **III. Specific Conditions**

#### **1. Payment of EMD:**

The Tender must be accompanied by EMD as stated above, by means of a Demand Draft, drawn in favour of the Finance Officer, Pondicherry University, payable at Puducherry separately. The amount is refundable. The Small Scale units are exempted from payment of EMD provided they should enclose proof of their exemption Certificate issued by the competent authority.

#### **2. Payments terms:**

- Normally a letter of Credit will be opened for 90% of CIP price, on receipt of order acknowledgement. However, 100% of the LC also be considered, if the supplier provide Bank Guarantee towards performance Security for the 10 % of the total cost of the equipment to cover the Warranty Period.
- Bank charges in India shall be borne by the purchaser and outside India shall be borne by the contractor / supplier.

3. The offer must be in English. The rates should be indicated both in figures and words against item specified in the given table. It is preferable that the price be quoted in Rupees or in US Dollars or in major foreign currencies.

4. The total cost should be quoted for FOB as well as CIF – Pondicherry University.

5. However, the price quoted under FOB or should also include the following cost if they are required during the initial stage:

a) Local freight / insurance for Chennai airport to University laboratory.

b) Installation cost if any.

c) Cost of consumables which are required for the equipment for initial operation upto a reasonable time.

6. In case of the Principal supplier of Foreign country unable to meet the conditions stated at para no.4, the local agent / dealer should fulfill the above said conditions in respect of Local Insurance, Freight, safety transport and installation, etc.

7. The bidder from within India shall obtain the requisite approval for Imports etc., if required.

**REGISTRAR**

Date: 21/4/2015

**ANNEXURE - I**

**BANK GUARANTEE**

Pondicherry University  
Bharat Ratana Dr. B R Ambedkar Administrative Building  
R Venkataraman Nagar  
Puducherry 605 014

This guarantee made this \_\_\_\_\_ day of \_\_\_\_\_ 200\_ by \_\_\_\_\_ Bank having its Registered Office at \_\_\_\_\_ and one of its branches at \_\_\_\_\_ (hereinafter referred to as "the Guarantor" which expression shall, unless it be repugnant to the subject, meaning or context thereof, be deemed to mean and include its successors and assigns) in favour of the Pondicherry University, Puducherry 605 014 represented by its Registrar, having his office at R. Venkataraman Nagar, Kalapet hereinafter referred to as the "University" which expression shall include his successors in office for an amount not exceeding Rs. \_\_\_\_\_ (Rupees \_\_\_\_\_ only) at the request of M/s. \_\_\_\_\_ (more fully described hereunder)

2. Whereas the University has placed Work Order No: PU/ \_\_\_\_\_ dated \_\_\_\_\_ for \_\_\_\_\_

\_\_\_\_\_ with M/s. \_\_\_\_\_ having its office at \_\_\_\_\_ and hereinafter referred to as the "Contractor" which expression shall include their successors and assigns.

3. And whereas the Contractor has accepted and agreed to execute the work as per the work order as per undertaking / agreement dated \_\_\_\_\_ within the time stipulated and in the manner specified therein.

4. And whereas the University has called upon the Contractor to furnish Bank Guarantee for the sum of Rs. \_\_\_\_\_ (Rupees \_\_\_\_\_ only) for fulfillment of the said work as specified in the work order and as agreed to by the Contractor.

5. And whereas the Contractor has requested the Guarantor herein to furnish an irrevocable and unconditional Bank Guarantee in favour of the University for an amount of Rs. \_\_\_\_\_ as guarantee towards execution of the work as agreed to by the contractor to the University.

6. Now, therefore, we \_\_\_\_\_ Bank, the Guarantor herein, do hereby irrevocably and unconditionally Guarantee the payment to the University the sum not exceeding Rs. \_\_\_\_\_ (Rupees \_\_\_\_\_ only) in the event of any breach, failure, neglect or inability on the part of the Contractor in the execution of the said work, on demand without reference of the matter to the Contractor and without any prior consent of the Contractor, at all times throughout the period of execution of the work, without demur, cavil or argument or delay.

7. The Guarantor agrees and undertakes that the decision of the University as to whether the contractor has committed any breach of the obligation with respect to the work to be executed, and the quantum of amount therefore payable by the Contractor to the University in that regard, shall be final, binding and conclusive as against the Guarantor and the Guarantor shall make payment accordingly, on demand by the University.

8. The Guarantor further agrees and undertakes to pay to the University the amount demanded by the University irrespective of and notwithstanding any dispute raised by the Contractor in any suit or

proceeding before any judicial forum relating to the Contracted work and the Guarantor's liability under this Guarantee shall be absolute and unequivocal.

9. This Guarantee is issued subject to the condition that the liability of this Guarantor under this guarantee is limited to the maximum of Rs. \_\_\_\_\_ (Rupees \_\_\_\_\_ only) and the guarantee shall remain in full force up to \_\_\_\_\_ and cannot be invoked otherwise than by a written demand or claim by the University for the payment of the said amount by the Guarantor on or before \_\_\_\_\_ or any extended date as decided by the University.

10. This University shall have the fullest liberty without our consent and without affecting in any manner our obligations hereunder to vary any of the terms and conditions of the contracted work or to extend time for performance of the work by the Contractor. Any change to the contracted work shall not in any way release the Bank (Guarantor) from liability under this Guarantee and we waive notice of any such change. The University shall have full liberty to forbear or enforce any of the terms and conditions of the contracted work.

11. This Guarantee shall not be affected by any legal limitation, disability or other circumstances relating to the Contractor or the Guarantor.

12. This Guarantee shall be valid for the period upto \_\_\_\_\_ and shall extend further and beyond \_\_\_\_\_ for such period as determined by the University.

13. The Guarantor undertakes not to revoke this guarantee except with the previous consent of the University in writing.

14. Notwithstanding anything contained herein:

- Our liability under this guarantee shall be limited to Rs. \_\_\_\_\_ (Rupees \_\_\_\_\_ only)
- This guarantee shall be valid upto \_\_\_\_\_ and for such further period as determined by the University for fulfillment of the contract.
- We are liable to pay the guaranteed amount or any part thereof under this Bank Guarantee only and only if you serve upon us a written claim or demand on or before \_\_\_\_\_ or such extended period / date.

In witness whereof, this Guarantee has been executed by \_\_\_\_\_  
for an on behalf of the Bank (Guarantor) on the day, month and year first above written.

SIGNATURE AND SEAL

NAME OF THE BANK (GUARANTOR)

ADDRESS